



STORM TECHNOLOGIES, INC.

411 North Depot Street PO Box 429
Albemarle, NC 28002

Phone: 704/983-2040, Fax: 704/982-9657

www.stormeng.com



A Practical Approach to Biomass Firing

Dick Storm, PE, Senior Consultant, Storm Technologies, Inc.

There are many challenges in power generation today. Amongst them are:

- Currently lower natural gas prices - uncertain natural gas prices in the future
- Reduction of carbon emissions
- Swinging large coal unit loads down to low loads at night to accommodate alternative generation and the declining industrial sector load (traditionally base load demand)
- Public & government pressure to fire more renewable fuels
- Keeping America strong with reliable, reasonable cost electricity generated from fuels sourced from within our borders

If these challenges force plants to utilize renewable fuels such as biomass, here are three suggestions to make the best of what we have in installed capacity with ever more difficult regulations:

1. Add high turn-down burners that use wood waste or other renewable fuels for low load operation at night. This is an idea that can be implemented at a reasonable cost and can help meet the requirements to fire alternative fuels, including biomass.
2. Improve heat rates by reducing air in-leakage and improving air pre-heater performance.
3. Establish a performance preservation program to work toward performance driven maintenance.

Here are two reasons for item No.1 – retrofitting with high turn-down burners:

1. With the economic recession, low gas prices and

reduced industrial production, the system loads for many utilities and IPP's require deeper load swings at night due to less base load industrial demand and a larger portion of electrical demand being from residential and commercial customers. The reduced nighttime demand is compounded by presently low natural gas prices. Therefore, the ability to turn large coal units down to lower loads and keep the "spinning reserves" of large coal units is important.

2. It appears that further laws and pressure to burn more renewable fuels is a reality. So, if we have to burn waste wood, chicken litter or other alternative fuels, why not do it in hybrid burners at night at low loads when the furnace residence time is greatest?

Here is an option on how a unit can be retrofitted at a reasonable cost. Please see Figure 1 - a typical pulverized coal fueled utility boiler retrofitted for hybrid fuels capability:

Here are four reasons why we think retrofitting large pulverized coal boilers for firing biomass is a practical concept:

1. Approximately 72% of the total electricity in America is generated by thermal power generation of coal, natural gas and oil fuels. Using biomass in a thermal plant utilizes existing steam plant installed capacity.
2. Of the approx. 72% thermal electricity production, approx. 50% is generated by coal. Therefore, a great opportunity exists to utilize our existing power generating infrastructure for firing alternative fuels. (coal plant installed capacity about 335,000 Megawatts and the grid is already built to distribute power from these about 570 plants)
3. The average age of pulverized coal plants is over 35 years old, but they are proven to be reliable, rugged and capable of extended life making retrofitting a cost efficient option.

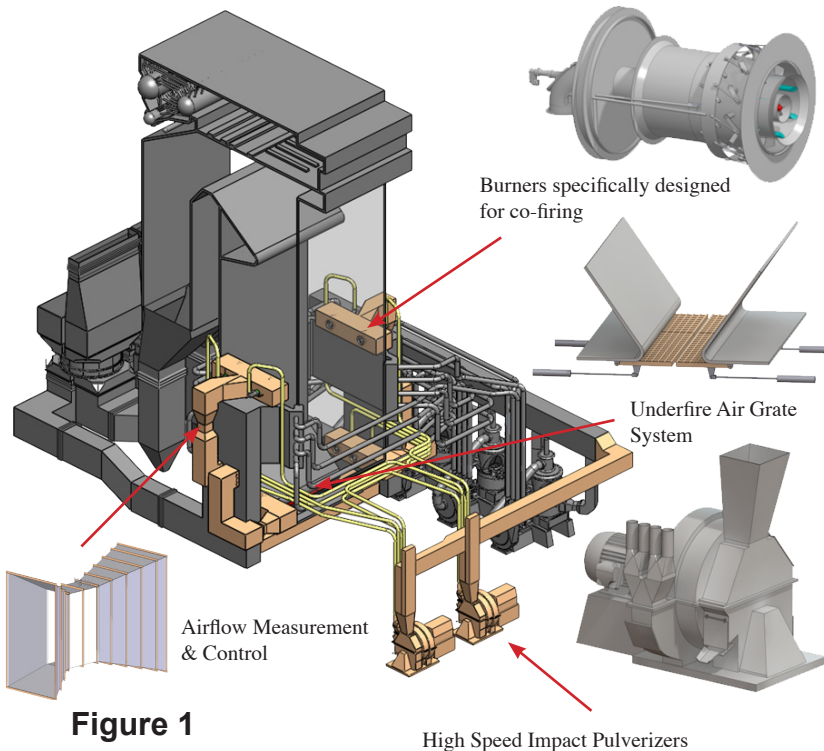

Figure 1

If the retrofitting of alternative fuels could be linked to the removal of New Source Review (NSR) restrictions, then it would seem that all sides of the issue could be satisfied. Alternative fuels could be used while existing plants would have the freedom to install new boiler surfaces, correct casing leaks and install new upgraded airheaters and other plant improvements. Imagine what we could do for lowering the costs of electric power production were it not for NSR? This could really make a difference and I think a large number of us writing Congress could persuade some common sense to prevail. Inspire your friends and neighbors to write your congressmen to abolish New Source Review.

4. While addressing the hybrid alternative fuels concept, the operation during off peak periods can be designed to utilize stable, low load gas burners and smaller capacity pulverizers at lower loads (Figure 1).

Regardless of the fuel fired, firing it well should be our top priority. Please let us know if you would like more information on retrofitting your boiler for biomass fuels. And even if this is not an option for your plant, we would still love the opportunity to discuss our heat rate improvement and performance driven maintenance programs with you.

Sincerely,



Richard F. Storm
Senior Consultant
Storm Technologies Inc.

On the subject of using our “Carbon Neutral Forests for Fuel,” let me throw in a review of the history of energy, just to put biomass use in thermal power generation in perspective. The following is taken from the introduction to the book, “Power to Save the World, the Truth about Nuclear Energy” by Gwyneth Cravens. This is authored by Richard Rhodes:

“Energy transitions take time. One example is the historic substitution of coal for wood, which was fundamental to the Industrial Revolution. Coal had been known and used for three thousand years, but only marginally. The inhabitants of sixteenth-century London, however, suffered from a problem familiar to conturbations in developing countries today: as the city grew, a greater and greater area around it became deforested, and as transportation distances increased, wood became more expensive. The poor had to switch to coal, the rich followed later.

A second major energy transition originated in the United States. In the mid nineteenth century, petroleum was first used as a substitute for whale oil for illumination in the form of kerosene. At the beginning of the twentieth-century, coal still accounted for more than 93% of all mineral fuels consumed in the United States, and electric light was rapidly displacing the kerosene lantern in urban America, with eighteen million lightbulbs in use in 1902. Large oil fields were discovered in Texas and California early in the century. Railroads in the

west and southwest almost immediately converted to oil burning, because local oil was cheaper than distant coal when transportation costs were figured in. That conversion prepared the way for the use of gasoline in automobiles.”

Here is a short math exercise: If tree farms can produce an average of 10 tons of wood per year per acre, then how many acres will it take to replace 200,000,000 tons of coal per year? (A little less than 20% of our coal production in America of about 1,100,000,000 tons per year) Two more thoughts; remember that biomass is much less dense than coal (wood chips about 18 pounds per cubic foot) and much less heating value per pound (wood is generally accepted to be about 8,500 Btu’s per pound oven-dry and below 5,000 Btu’s per pound with high moisture content). Hint, take a look back into history such as the 19th century energy use and then factor in our energy consumption for transportation needs to keep our economy humming and also “Living Better Electrically” to today’s standards of living.

Storm Technologies, Inc. works hard to educate the public (and especially school age children) on matters of Energy and Economics. We have always been strong supporters of energy from within America’s borders and including all forms, coal, nuclear, natural gas, oil and renewable. All of the above are important for America to remain strong and understanding the realities and myths of renewable power should be better understood by policy makers. A key point about America’s energy use, about 93% of our energy is still used in “Heat Engines” whether for transportation or electricity generation. Those of us that understand the relationship of energy and economic prosperity have a professional responsibility to teach the uninformed and the misguided the true facts on the subject of Energy and Economic Prosperity. Building a better world of increased improvements in humankind depends on wise and efficient use of all forms of energy.

These opinions are those of Richard F. (Dick) Storm, PE and not necessarily of Storm Technologies, Inc.

The logo for FABRICATED SOLUTIONS features the word "FABRICATED" in a red, serif font above the word "SOLUTIONS" in a blue, serif font. The letters "S" and "O" in "SOLUTIONS" are stylized to resemble mechanical gears or bolts.

Fabricated Solutions (a division of Storm Technologies, Inc.) continues to be a leader and innovator among steel fabricators and machining services. We specialize in ASME code work, ductwork (new or replacement) and large diameter pipe in addition to our STORM performance components (i.e. pulverizer components, airflow management, etc.). Our fabrication shop is conveniently located within 35 miles of the greater Charlotte, NC area to serve large industrial and power generation needs regionally and nationally as well. Our shop is ready to support and meet the expedited needs of your plant and we look forward to the opportunity to work with your next fabrication/machining project. Our shop is proud to practice the Storm mantra – SERVICE – QUALITY – RESULTS!

Things to Consider in Co-firing with Biomass

It seems that every day we hear more and more about “biomass” and renewable fuels. Environmental groups and many politicians are advocating the use of biomass. So let us take a few moments and discuss biomass and why it should be considered and what the advantages and disadvantages are:

First, biomass fuels are fuels derived from living (or once living) organisms such as wood, waste and alcohol. These fuels are used to generate electricity or heat. While traditional fossil fuels are also derived from organic matter, they are not considered renewable due to the geologic process in converting the matter to coal or oil.

Next, you might be thinking, why should we use biomass fuels? There are several advantages:

- Biomass fuels produce virtually no sulfur emissions and require no scrubbers or reagents to help mitigate acid rain.
- Biomass fuels “recycle” atmospheric carbon, minimizing manmade carbon dioxide emissions since zero “net” carbon dioxide is considered emitted during biomass combustion, i.e. the amount of carbon dioxide emitted is equal to the amount absorbed from the atmosphere during the biomass growth phase.
- The recycling of biomass wastes mitigates the need to create new landfills and extends the life of existing landfills.
- Biomass combustion produces less ash than coal and reduces ash disposal costs and landfill space

requirements. Biomass ash when fired alone can also be used as a soil amendment in farm land.

- Perennial energy crops (grasses and trees) have distinctly lower environmental impacts than conventional farm crops. Energy crops require less fertilization and herbicides and provide greater vegetative cover throughout the year, providing protection against soil erosion and watershed quality deterioration, as well as improved wildlife cover.
- Landfill gas-to-energy projects turn methane emissions from landfills into useful energy.

All of this sounds good, but like most things in life, there are some disadvantages too. They include:

- Lower heating value and high moisture result in high consumption rates, which increase material handling.
- Obtaining a reliable supply chain to replace a significant amount of coal will be difficult. It takes about six rail cars of biomass to replace the equivalent of one rail car of coal energy.
- Although considered carbon neutral, biomass still produces carbon dioxide and other greenhouse gases and will burn at lower efficiency due to the moisture content.
- It takes up more water from the earth and other fossil fuels to make the fertilizers and fuels for planting and harvesting.
- It also will take up more land that could have been used for crops and trees.
- Biomass collection, storage and treatment are difficult.
- It can lower the efficiency of boilers when it is used by plants which mix it with other combustible materials.

MPS Pulverizer Recommendations

Gravimetric feeder equipped with microprocessor & load cell technology

Synchronized STORM Straight Vane Coarse Particle Guide Blades

Each of the pulverizers must have an access door so that inspections, synchronization and adjustments can be completed “as needed” to the classifier

Clearances similar with no ledges: optimize opening to be determined by STORM

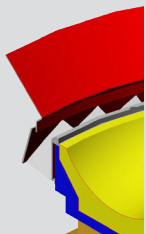

STORM design rotating throat and deflector to improve primary classification. STORM design rotating throats will insure optimum upward velocity, improved primary classification and reduced coal rejects.

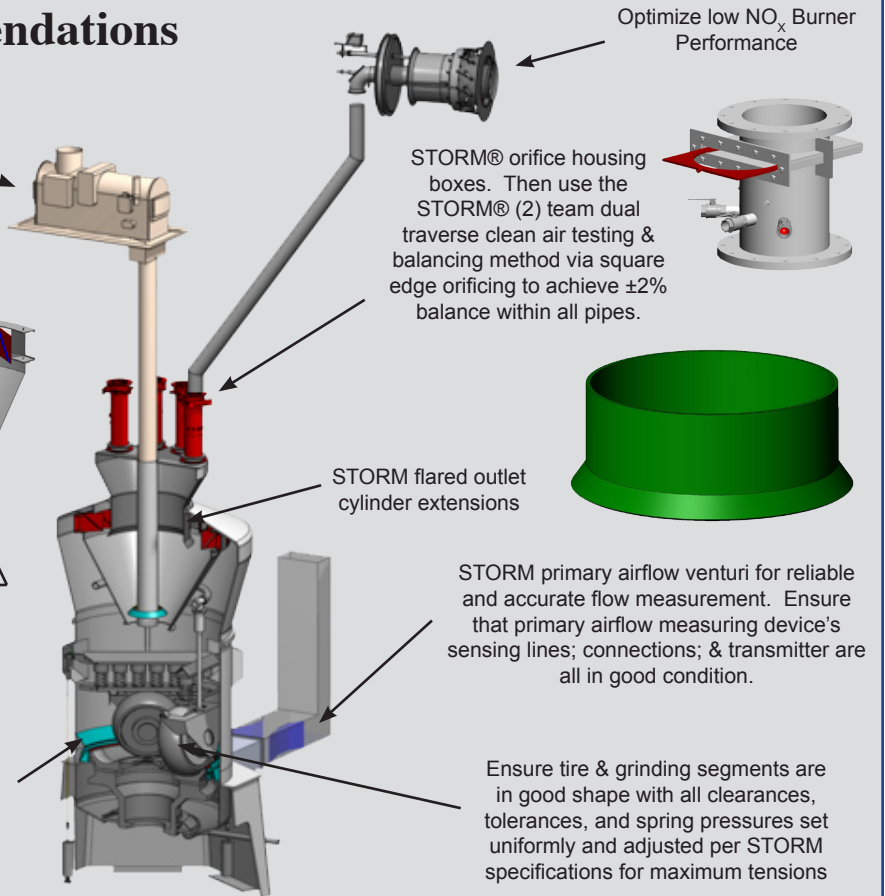

Optimize low NO_x Burner Performance

STORM® orifice housing boxes. Then use the STORM® (2) team dual traverse clean air testing & balancing method via square edge orificing to achieve ±2% balance within all pipes.

STORM flared outlet cylinder extensions

STORM primary airflow venturi for reliable and accurate flow measurement. Ensure that primary airflow measuring device's sensing lines; connections; & transmitter are all in good condition.

Ensure tire & grinding segments are in good shape with all clearances, tolerances, and spring pressures set uniformly and adjusted per STORM specifications for maximum tensions

- It requires a large space to be stored correctly.
- Biomass if used in large quantities from forest products will likely increase timber and wood pulp costs just as ethanol production increased corn prices, therefore harming the economy for building and paper products.

After weighing the pros and the cons, if your facility decides to use biomass by co-firing (blending the fuels with the coal at the coal-fired boilers), you must remember this key point about co-firing biomass: co-firing operations are not implemented to save energy; they are implemented to comply with renewable power standards and federal or state regulations, not to reduce energy costs or to improve facility operations. Reduced production costs from co-firing biomass are unlikely; reduced fuel costs may be possible in some localities by (1) replacing a fraction of higher-cost fuels with low-cost biomass and (2) reduced disposal costs. When used as a supplemental fuel in an existing coal boiler, biomass may provide some benefit such as reduced fuels costs, lower sulfur oxide (SO_x) and nitrogen oxide (NO_x) emissions, lower landfill costs and reduced greenhouse-gas emissions.

However, the realities are that production and operations and maintenance costs will increase with the use of biomass. For example, there are some disadvantages with slagging, fouling and corrosion being the most noticeable ones. A number of biomass fuels have high alkali and/or chlorine content. This combination can lead to unmanageable ash deposition problems on the heat exchange surfaces. Moreover, chlorine in combustion gases can accelerate corrosion of combustion systems and flue-gas cleaning components. Similarly, NO_x emissions may be increased with co-firing due to the increased furnace excess oxygen content needed to complete the burning of larger fuel particles in the available residence time.

In addition, there will have to be changes to the process. Certain equipment will have to be retrofitted to handle the biomass fuels (such as the concept shown in Figure 1). One cannot just “throw in” some wood chips or chicken litter in the pulverizer and expect everything to work. Modifications to the equipment and process will have to be implemented in order to maximize fuel handling efficiency and the effectiveness of combustion. Essentially, the process will need to change so that the limited available residence time is used to combust slower burning and larger particles of fuel.

Another issue that can have a negative economic effect on the facility is the ash markets. Concrete admixtures represent an important market for some companies considering the combustion ash by-products. Current ASTM standards for concrete admixtures require that the ash be 100% coal ash. Thus, the conversion/addition of biomass can have serious impact on the ability to utilize flyash for construction. This can have a very negative impact on coal ash utilization and the ability to sell coal ash.

Finally, there are logistical and storage considerations. Biomass is larger (greater volume per cubic foot) than coal for an equivalent amount of heat energy. Thus, it will take more storage space. In addition, because biomass absorbs more water than coal, the fuel will have to be covered. Moreover, since some biomass fuels are reactive, fire

suppression systems may need to be upgraded.

So, the \$64,000 question (really it's a lot more than that) is should your facility implement co-firing of biomass? There are many facilities that have implemented co-firing with biomass and increased profitability. The answer depends on the details. If you expect the co-firing to lower your production costs, then think again. However, if all of the costs of co-firing biomass are understood, then it is worth considering.

The concept outlined in this newsletter is one way to co-fire biomass in existing boilers designed and proven to fire pulverized coal very efficiently and effectively.

Regardless, there is a movement by the press and the public to use more renewable fuels. You may be able to score a few points in the public relations battle and still produce electricity at competitive rates. When competing with high cost solar, wind and other renewables, co-firing biomass could be more economically feasible than other alternative fuels. Biomass is likely to be significantly more costly than coal as a fuel.

Just as there is no free lunch, biomass electricity production will cost more than power from traditional fossil fuels. Our experience in furnace combustion includes years of working with wood waste and bark fueled boilers in the pulp and paper industry as well as boilers firing municipal solid waste. So, our experience in biomass firing can be tapped to combine with your engineering department expertise.

At Storm Technologies, we can assist you in making changes to your facilities to implement co-firing with biomass fuels.

FROM CONCEPT TO COMPLETION

SOLIDWORKS CFD FEA TECHNICAL DIRECTION