



STORM TECHNOLOGIES, INC.
 411 North Depot Street PO Box 429
 Albemarle, NC 28002
 Phone: 704/983-2040, Fax: 704/982-9657
 www.stormeng.com



2009 Spring/Fall Outage Planning and Cost Effective Results:

Our January newsletter focused on PERFORMANCE/DRIVEN/MAINTENANCE. This month we wanted to update our customers on our manufacturing capabilities. As discussed in that newsletter, our fabrication shop is in full operation and now fully capable of manufacturing all of the components we have provided over the past 15-20 years. Some common areas in performance driven maintenance can be addressed by reviewing the INPUTS.

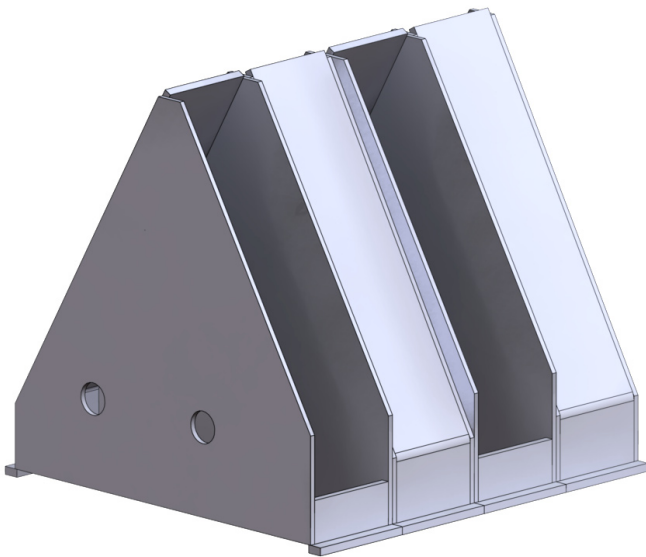

Figure No. 1 (Original "Coarse Cut" Riffles)

For example: Some vertical spindle type pulverizers (suction and pressurized) are equipped with riffles that are prone to wear and should be inspected and replaced as needed. Some of the riffles are manufactured from thin materials which will wear out quickly; new heavy duty fine cut riffles provided by STORM are nearly 50% thicker and have solid dividers. Many original riffles have poor performance. For a case example, the following table indicates where "coarse cut" riffles (Figure No. 1) were in all of the following Mills with the exception of "fine cut" riffles (Figure No. 2) were installed in Mill D. As you can see the distribution is clearly better for Mill D (Figure No. 3).

The point of this is that the riffle replacements are part of the normal outage work scope. By installing the new heavy duty fine cut riffles provided by STORM, distribution was improved. If classifier work and other proper clearances and settings are completed, further improved fuel fineness and distribution can be achieved without much additional outage work scope. In addition to the normal wear and tear items such



Figure No. 2 (New Riffles)

as the proposed riffles, we have also successfully replaced the thick original cast venturi orifice with an orifice housing assembly. They require minimum installation work where they can be installed between the Victaulic type couplings located just on top of the secondary riffles as shown on the following page (Figure No. 4).

If the plant should be interested in boiler efficiency, performance and reliability, especially with coal costs at \$100+/Ton, the pulverizers MUST be optimized and STORM can help with classifier, rotating throat/deflector, and airflow measurement improvements (Figure No. 5 Concept Overview).

Thirteen Essentials of Optimum Combustion for Low NO_x Burners

1. Furnace exit must be oxidizing preferably, 3%.
2. Fuel lines balanced to each burner by "Clean Air" test $\pm 2\%$ or better.
3. Fuel lines balanced by "Dirty Air" test, using a Dirty Air Velocity Probe, to $\pm 5\%$ or better.
4. Fuel lines balanced in fuel flow to $\pm 10\%$ or better.
5. Fuel line fineness shall be 75% or more passing a 200 mesh screen. 50 mesh particles shall be less than 0.1%.
6. Primary airflow shall be accurately measured & controlled to $\pm 3\%$ accuracy.
7. Overfire air shall be accurately measured & controlled to $\pm 3\%$ accuracy.
8. Primary air/fuel ratio shall be accurately controlled when above minimum.
9. Fuel line minimum velocities shall be 3,300 fpm.
10. Mechanical tolerances of burners and dampers shall be $\pm 1/4"$ or better.
11. Secondary air distribution to burners should be within $\pm 5\%$ to $\pm 10\%$.
12. Fuel feed to the pulverizers should be smooth during load changes and measured and controlled as accurately as possible. Load cell equipped gravimetric feeders are preferred.
13. Fuel feed quality and size should be consistent. Consistent raw coal sizing of feed to pulverizers is a good start.

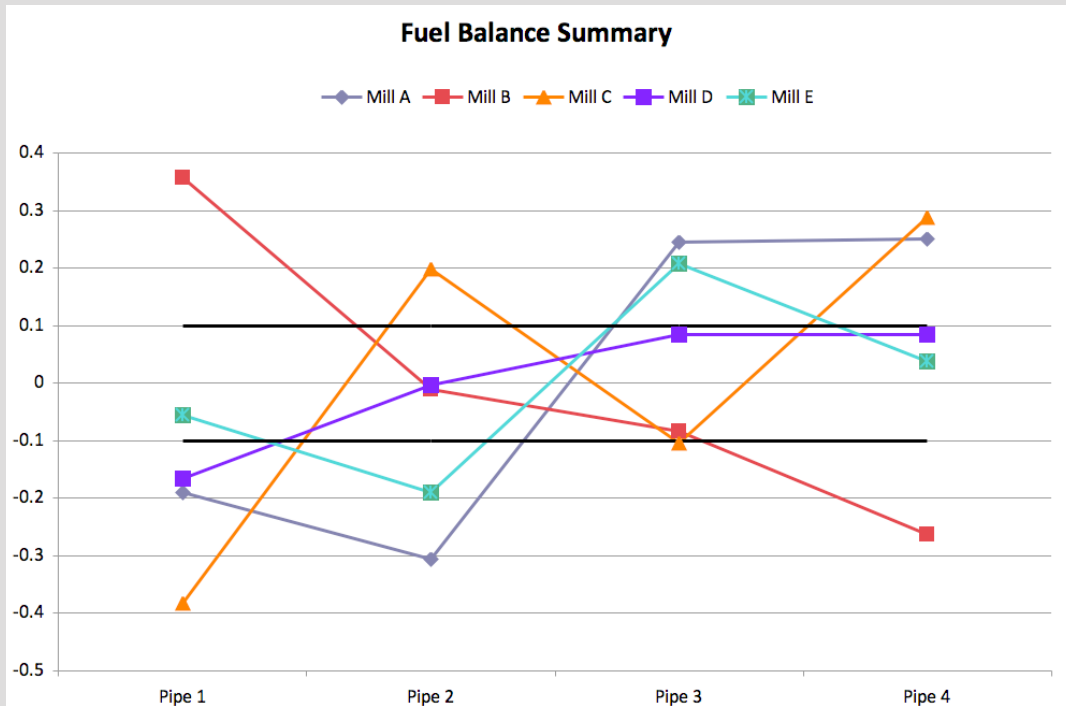

**Figure No. 3 - Fuel Balance Summary – Fine Vs. Coarse Cut Riffles
(Heavy duty fine cut riffles provided by STORM in Mill D Only)**

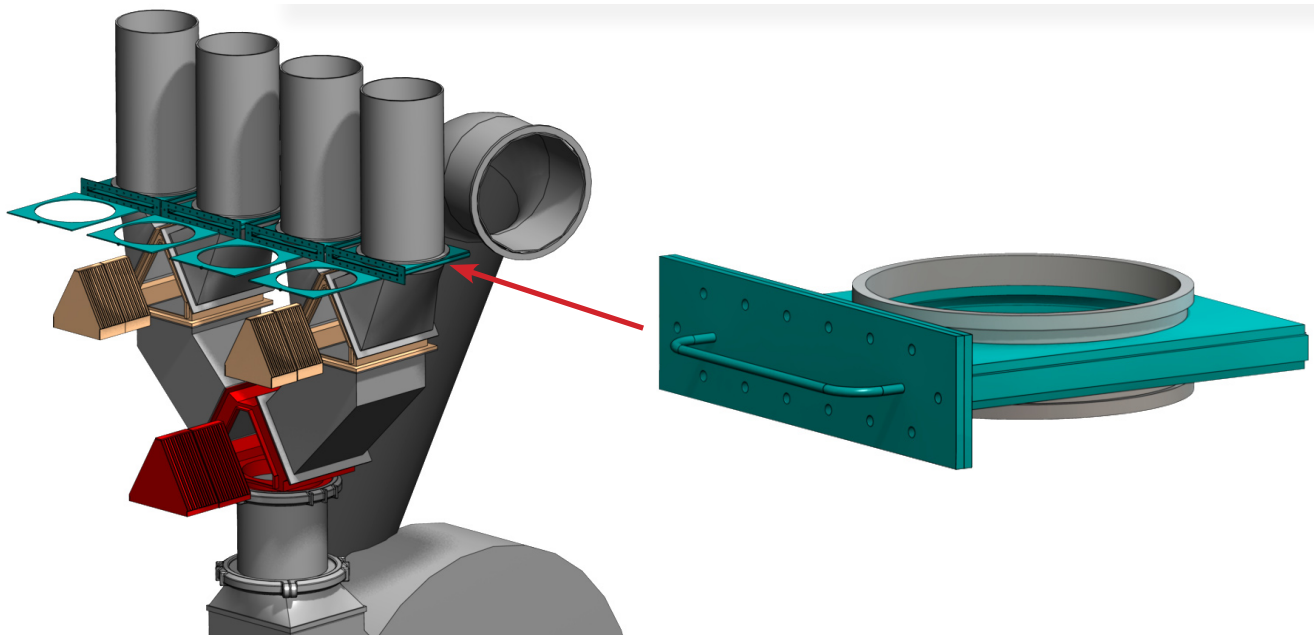

Figure No. 4 – Heavy duty fine cut riffles provided by STORM and Orifice Box Concept

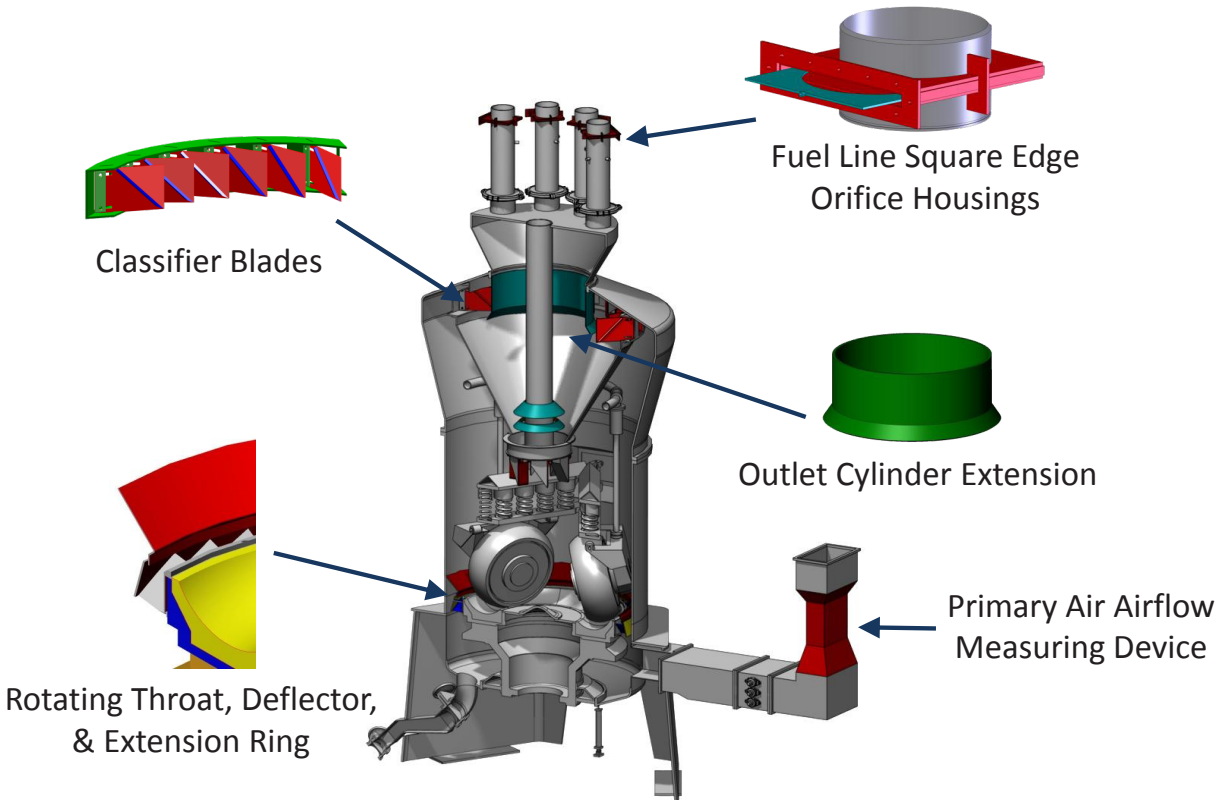

Figure No. 5 – Pulverizer Performance Concept Overview

Why PERFORMANCE/DRIVEN/MAINTENANCE is so Important:

- Improved Heat-Rate and Efficiency
- Reduced LOI (carbon in ash)
- Reduced Furnace Slagging
- Reduced NO_x and Fan Capacity by Balancing Fuel/Air to the furnace.
- Reduced Superheat & Reheat Sprays
- Improved Fuel Flexibility
- Reduced SCR and Backpass Fouling
- Improved Unit Reliability and Forced Outage Rate

9 of our 13 Essentials noted on the previous page deal with pulverizer performance (blue) and this is why maintenance of the pulverizers is so critical and require performance as shown in Figure No. 5.

The previous components can be accomplished by working closely with STORM to set proper clearances and settings along with some performance components. STORM can assist you with technical direction and fabricated components to achieve SERVICE/QUALITY/RESULTS.

With our new fabrication facility, we are able to control our schedule and costs to be competitive at the same time we are achieving SERVICE/QUALITY/RESULTS.

Some of our capabilities include but are not limited to the following:

- Orifice Box Housings
- Replacement Riffles
- Rotating Throats and Deflectors
- Classifier Blades
- Outlet Cylinders
- Primary Air Measurement Devices
- Secondary Air Measurement Devices
- OFA Measurement Devices
- Ceramic Lined Fuel Pipes
- Plasma Cutting and Machining
- Duct work Replacement Sections
- Chordal Thermocouples
- Oil and Igniter Tips
- Averaging Pitot Tube Arrays
- Classifier cones, etc.
- Carbide Overlay Plate
- Multi point Flyash sampling emission grid
- Multi Point Probes for boiler tuning
- All Diagnostic Testing Equipment

Material is in stock for the majority of the above items (excluding any machining services) and could be started within 8 hours or less from when an order is placed.

PERFORMANCE - DRIVEN - MAINTENANCE and SERVICE - QUALITY – RESULTS

SERVICE/QUALITY/RESULTS is nothing new to STORM. However, our challenge is to express to our customers the importance of PERFORMANCE/DRIVEN/MAINTENANCE working along with SERVICE/QUALITY/RESULTS.

Our components are not worth anything unless we have ownership from the performance and maintenance team at the plant. The maintenance team wants the part to last forever and the performance team will want good unit efficiency, reliability, and performance, and STORM needs everyone and it will take a TEAM effort to make this happen as it needs to.

Now with manufacturing capabilities, our parts are only good if we have good synergy with our team and the plant to ensure that they are installed and operated correctly. Without this synergy, our parts will not work correctly or they will be operated in a less than efficient manner. Today, with fuel costs and quality challenges, it is even more important to get the inputs right of which we have been pushing for decades.

In summary: STORM depends on our field services team to measure up the components, technically direct the installation as well as conduct start up tuning with plant personnel (i.e. operators, maintenance and

performance). So as you can see, it is critical to implement a plan from pre-outage to post outage to maximize unit performance, reliability and efficiency.

In the past, we have had instances where we have provided these recommendations to the plant and they were either implemented partially and/or incorrectly and this made no one look good. With our manufacturing capabilities, we can control our schedule, costs, etc. and have the technical support to ensure everything is correctly installed and operating as it should.

We have had our challenges and sometimes things do not go as planned, which is typical for a power plant. However, with SERVICE/QUALITY/RESULTS being our mantra, we will work with the customer through every challenge, or opportunity as we would call it, to achieve RESULTS. Very few customers have completed everything we recommended. However, the ones that have see payback in a short period of time with improved heat-rate and reliability.

Sincerely,



Danny Storm

Executive Vice President (Engineering & Fabrication)

STORM™ “Performance Driven Approach” is Condition Based Maintenance

